

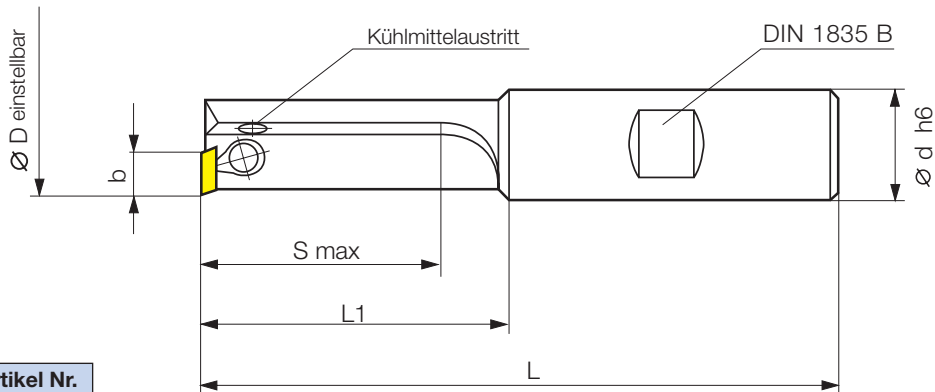

# Feinbohrwerkzeuge

Radialverstellung  $\mu\text{m}$ -genau einstellbar

1-schneidig  $\varnothing 7 - 20 \text{ mm}$   
zentrale Kühlmittelzufuhr



Artikel Nr.  
**20021**

Code	Zeichnungsnummer		b	$\varnothing D$	$\varnothing d$	S	L <sub>1</sub>	L	Schneidplatten
7,000	H 1035-0700 2016 R	●	3,9	7 - 8	16	20	28	76	W 1035-... L
8,000	H 1035-0800 2016 R	●	3,9	8 - 9	16	20	28	76	↓
9,000	H 1035-0900 2016 R	●	3,9	9 - 10	16	20	28	76	↓
10,000	H 2850-1000 2516 R	●	5	10 - 11	16	25	35	83	W 2850-... L
11,000	H 2850-1100 2516 R	●	5	11 - 12	16	25	35	83	↓
12,000	H 2850-1200 3016 R	●	5	12 - 13	16	30	40	88	↓
13,000	H 2850-1300 3016 R	●	5	13 - 14	16	30	40	88	↓
14,000	H 3570-1400 3516 R	●	7	14 - 16	16	35	45	93	W 357-...L
16,000	H 3570-1600 4016 R	●	7	16 - 18	16	40	50	98	↓
18,000	H 3570-1800 4516 R	●	7	18 - 20	16	45	55	103	↓

● ab Lager

Bestellbeispiel: 1 Stück H 1035-0700 2016 R = Bestellnummer: 20021 7,000



Ersatzteile  
Seite 48-49

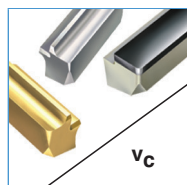

Geometrie- und  
Sortenauswahl  
Seite 59-60

# Feinbohrwerkzeuge

## Radialverstellung $\mu$ m-genau einstellbar



2-schneidig  $\varnothing$  10 - 40 mm  
zentrale Kühlmittelzufuhr

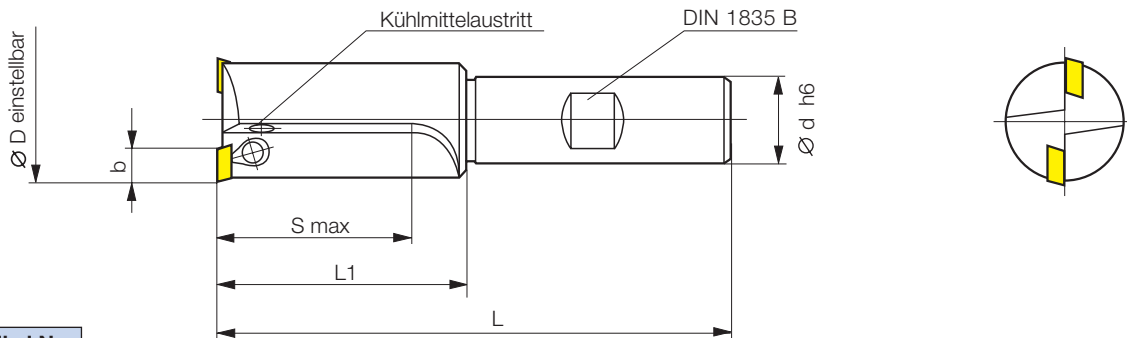

Artikel Nr. 20022									
Code	Zeichnungsnummer		b	$\varnothing D$	$\varnothing d$	S	$L_1$	L	Schneidplatten
10,000	H 1035-1000 2516 R	•	3,9	10 - 11	16	25	35	83	W 1035-... L
11,000	H 1035-1100 2516 R	•	3,9	11 - 12	16	25	35	83	↓
12,000	H 1035-1200 3016 R	•	3,9	12 - 13	16	30	40	88	
13,000	H 1035-1300 3016 R	•	3,9	13 - 14	16	30	40	88	↓
14,000	H 2850-1400 3516 R	•	5	14 - 15	16	35	45	93	W 2850-... L
15,000	H 2850-1500 3516 R	•	5	15 - 16	16	35	45	93	↓
16,000	H 2850-1600 4016 R	•	5	16 - 17	16	40	50	98	
17,000	H 2850-1700 4016 R	•	5	17 - 18	16	40	50	98	↓
18,000	H 2850-1800 4516 R	•	5	18 - 19	16	45	55	103	
19,000	H 2850-1900 4516 R	•	5	19 - 20	16	45	55	103	↓
20,000	H 3570-2000 5020 R	•	7	20 - 22	20	50	65	115	W 357-...L
22,000	H 3570-2200 5520 R	•	7	22 - 24	20	55	70	120	↓
24,000	H 3570-2400 6020 R	•	7	24 - 26	20	60	75	125	↓
26,000	H 4090-2600 6520 R	•	9	26 - 28	20	65	80	130	W 409-...L
28,000	H 4090-2800 7020 R	•	9	28 - 30	20	70	85	135	↓
30,000	H 4090-3000 7520 R	•	9	30 - 32	20	75	90	140	
32,000	H 4090-3200 8020 R	•	9	32 - 34	20	80	95	145	↓
34,000	H 4090-3400 8525 R	•	9	34 - 36	25	85	105	161	
36,000	H 4090-3600 9025 R	•	9	36 - 38	25	90	110	166	↓
38,000	H 4090-3800 9525 R	•	9	38 - 40	25	95	115	171	↓

● ab Lager

Bestellbeispiel: 1 Stück H 1035-1000 2516 R = Bestellnummer: 20022 10,000

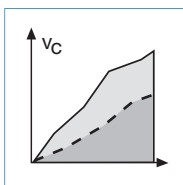

Anwendungsempfehlungen  
Seite 61

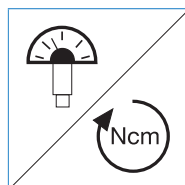

Einstellanweisung  
Seite 50

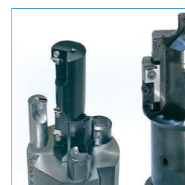

Anfrageformular für kundenspezifische Werkzeuge  
Seite 108